

APPLICATION AREA

Radial shaft seals, also known as simering or oil seals, are used in areas where perfect insulation and protection between the rotating shaft in oily or greasy environment and the outside world is an important aspect. These seals are essentials in preventing the leakage of fluids, oils and other substances while still allowing the shaft to move.

Automotive: radial shaft seals are used in engines, transmissions and wheel axles to prevent oil leakage.

Mechanical Industry: these seals are used in many parts of industrial machines and equipment, for example in the shafts of pumps, compressors and rotating machines.

Food Industry: in the food industry, especially in machines where hygiene and a clean environment are important, radial shaft seals are used, for example, in the shafts of mixers and packaging machines. The FDA means in product name the fulfilment for regulation of Food and Drug Administration and these products are surely applicable in food industry.

TECHNICAL DESCRIPTION OF RADIAL SHAFT SEALS MANUFACTURED AND DISTRIBUTED BY KTT

DIMENSIONING

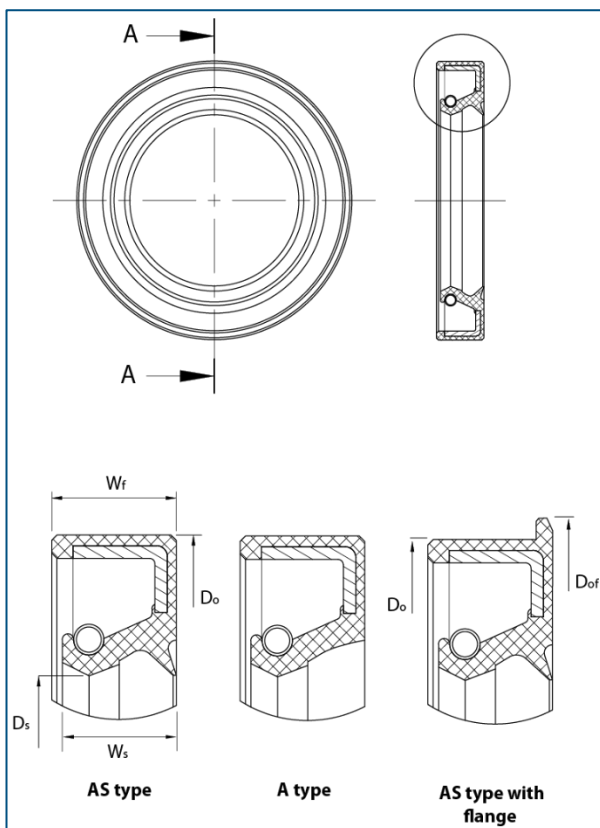

Typical dimensions:

Ds =	shaft diameter (nominal inside diameter)
Do =	outside diameter
Dof =	outer diameter of flange
Wf =	press fit width
Ws =	width on shaft surface

Rule of dimensioning: Ds x Do x Wf (default case)

Rules of dimensioning in special cases:

Ds x Do x Wf / Ws: in the case of pressure-resistant type oil seals (BABSL), it is important that the width on the shaft side (Ws) is as small as possible, that's why it is marked separately.

Ds x Do / Dof x Wf: in the case of oil seals with flange, when a flange extends beyond the external diameter what is important for fitting, the flange outer diameter (Dof) is indicated. The product range of KTT Sealing Technologies includes some oil seals with flange what produced for special needs.

Abbreviations:

AS =	radial shaft seals with rubber housing and dust protection lip	according to DIN 3760 and
A =	radial shaft seals with rubber housing without dust protection lip	DIN 3761 standards

The main production profile of KTT is the manufacturing of A - oil seals without dust protection lip and AS - oil seals with dust protection lip with metal reinforced rubber housing design according to standard DIN 3760 and DIN 3761.

OTHER COMMON RADIAL SHAFT SEAL TYPES

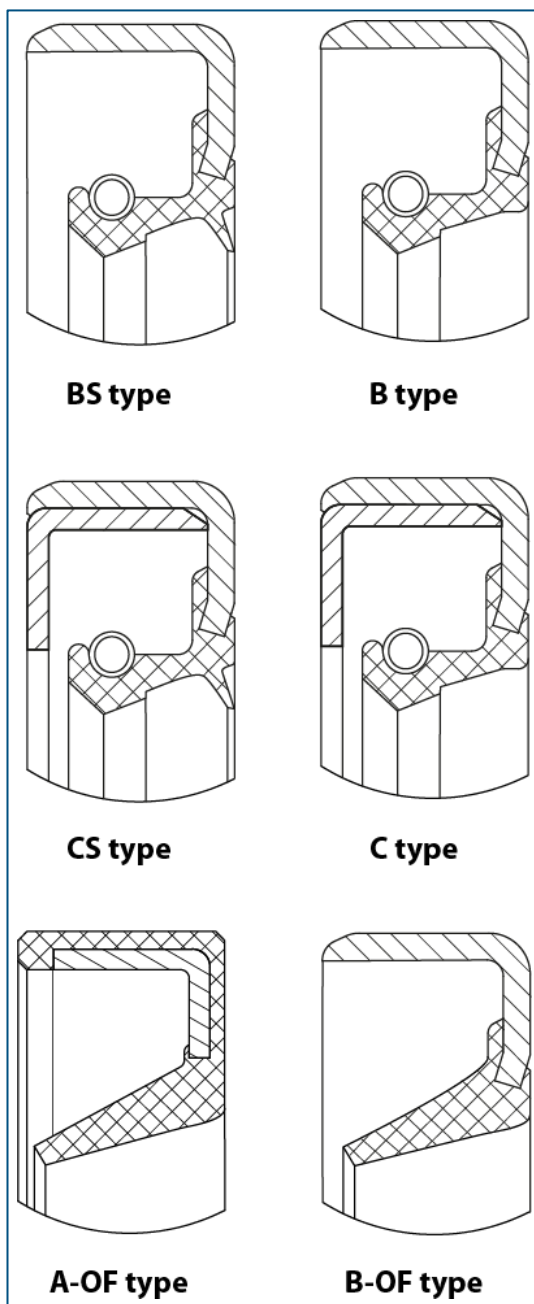

Abbreviations:

BS =	radial shaft seals with metal housing and dust protection lip	according to standard DIN 3761
B =	radial shaft seals with metal housing without dust protection lip	
CS =	radial shaft seals with closed metal housing and dust protection lip	
C =	radial shaft seals with closed metal housing without dust protection lip	
A-OF =	radial shaft seals with rubber housing without spring and dust protection lip	
B-OF =	radial shaft seals with metal housing without spring and dust protection lip	

Additional properties:

Housing with grooved outer surface

In the case of rubber housing oil seals, in addition to the smooth outer surface, manufacturers often use a grooved outer surface, which helps with more flexible fixation during installation.

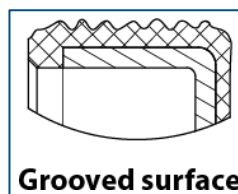

Radial shaft seals with oil leading channel (drall)

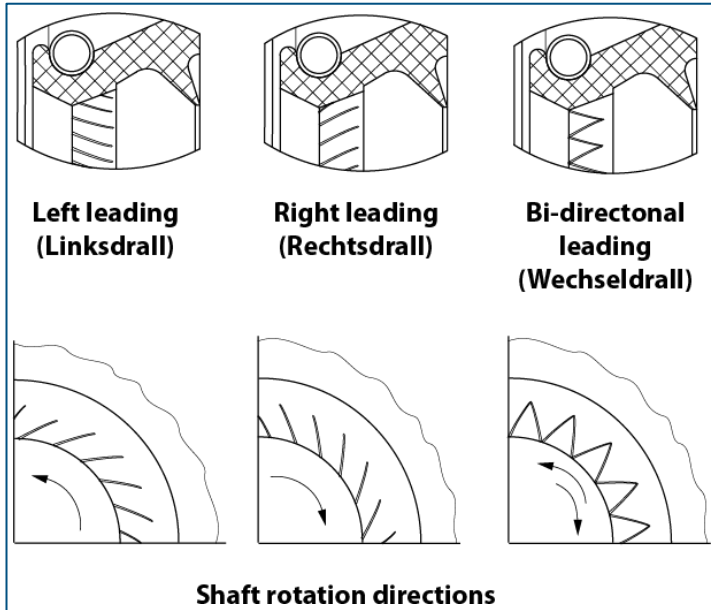

Radial shaft seals that are equipped with an oil return channel are called Left or Right leading type oil seals and also called as "drall" from Germanian naming. There are small notches on the back surface of the sealing lip, which pump the oil from the surface of the rotating shaft back to the inner side of the sealing edge during rotation. It is very important that this kind of special radial shaft seals is selected according to the direction of rotation of the shaft.

CHOOSING THE RIGHT SHAFT SEALS

Most of the shaft seals we produce are first installed (OEM), but unfortunately we regularly find that even here the installation conditions are still not satisfactory. Our experience is even worse when it comes to replacement parts, although these shaft seals will have to stand up to even more demanding conditions. Therefore, we will briefly summarise what is required by the EU DIN 3760 standard and practice.

NOMOGRAM FOR ROTATION SPEED – SHAFT DIAMETER

If the heat and chemical resistance of FKM is not sufficient, PTFE with metal housing is the right solution.

When fitting, it is important that both the shaft to be sealed and the bore of the sealing ring are provided with a suitable conical groove and radius. For installation, use a tool that presses the seal in as close as possible to the outside diameter. Ensure that the sealing edge is perfectly perpendicular to the shaft.

Don't insist on the same height as the original on a replacement part, it is unprofessional to "run" the seal on an imperfectly rebuilt axle in the same place where its previous part damaged it. Perfectly reconditioned shafts are rare, because new ones do not always meet the standard: they must have a roughness depth of 4 microns and a hardness of 55 HRC at 0.3 mm depth. In addition to the obligatory rigidity already mentioned at the time of installation, three geometric factors can impair the perfection of the seal:

- The centre line of the bore of the shaft seal and the shaft must not diverge. The "culprit" for this is the edge – that is worn on one side when the axle is removed.
- Only very small shaft ovality are allowed.
- A shaft run-out of more than 0,1 mm even at medium speeds can only be sealed by means of a back pressure groove (on other names: leading pattern or drall).

The shaft seal must not be subjected to a pressure of more than 0.5 bar. This must be kept to even if the sealing lip does not turn out, as high pressures cause wear and heat build-up, and even distort the life of the sealing lip in the wrong geometry. It follows that FKM tolerates small overpressures better. We offer Simrit BABSL models, these are pressure resistant up to 10 bar, but wear faster at higher speeds.

RECOMMENDEN ELASTOMETERS FOR THE RADIAL SHAFT SEALS DEPENDING ON THE ROTATION SPEED AND SHAFT DIAMETER

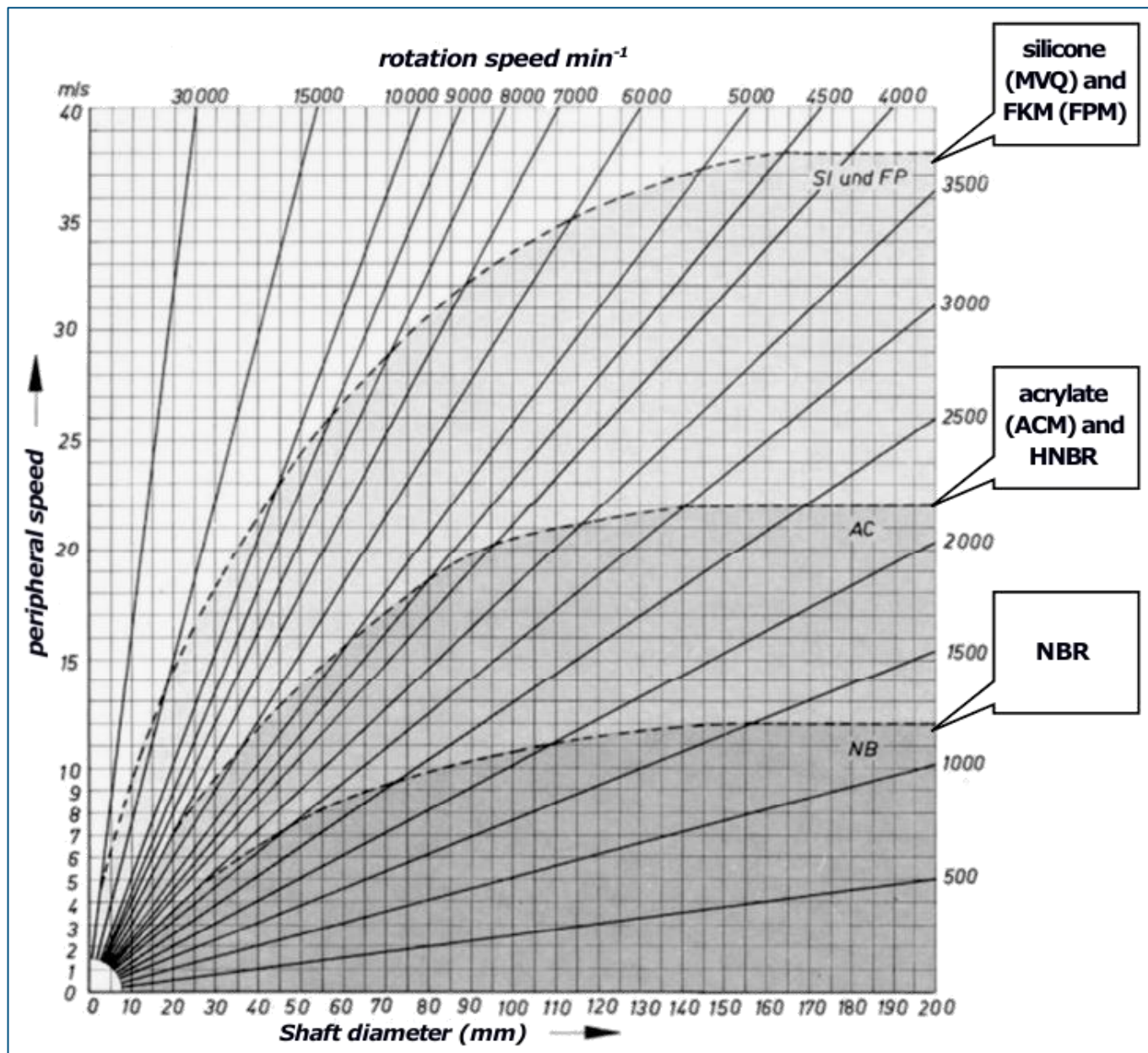

EU DIN 3760 REQUIREMENTS FOR THE OVERLAPPING OF THE OUTER DIAMETER OF SHAFT SEALS

outer diameter (mm)	overlapping	permitted deviation from circularity
50-	+0,30 +0,15	0,25
50-80	+0,35 +0,20	0,35
80-120	+0,35 +0,20	0,50
120-180	+0,45 +0,25	0,65
180-300	+0,45 +0,25	0,8
300-500	+0,55 +0,30	1,0

EU STANDARD DIN 3761 SPECIFICATIONS FOR SURFACE ROUGHNESS IN THE INSTALLATION ENVIRONMENT OF SHAFT SEALS

Shaft surface roughness

$R_a =$	0,2-0,8 μm
$R_z =$	1-5 μm
$R_{\text{max}} =$	$\leq 6,3 \mu\text{m}$

Borehole surface roughness

$R_a =$	1,6-6,3 μm
$R_z =$	10-20 μm
$R_{\text{max}} =$	$\leq 25 \mu\text{m}$

Main properties and characteristics of the most commonly used vulcanised rubber types

	NBR Nitrile rubber	HNBR Hydrogenated Nitrile Rubber	Silicone (VMQ, MVQ) Vinyl silicone	Viton (FKM, FPM) Fluorine rubber	EPDM Ethylene-Propylene-Diene Rubber
Hardness (Shore A)	60-90	60-90	60-90	60-90	40-90
Heat resistance (°C)	(-50) ... -30 ... +100*	(-50) ... -30 ... +150*	-55 ... +210	-25 ... +200	-40 ... +150
Tensile strength	good	excellent	poor	medium	good
Elongation	good	good	excellent	medium	good
Elasticity	medium	medium	good	insufficient	good
Tear resistance	medium	poor	not recommended	not recommended	medium
Wear resistance	excellent	excellent	not recommended	poor	good
Residual deformation	medium	medium	insufficient	insufficient	not recommended
Gasoline	medium	medium	not recommended	excellent	insufficient
Mineral oil	excellent	excellent	medium	excellent	insufficient
Inorganic acids	medium	medium	medium	excellent	not recommended
Inorganic alkalis	poor	medium	not recommended	excellent	poor
Hot water	medium	good	medium	excellent	poor
Ozone, weather	not recommended	excellent	excellent	excellent	poor
Applicable medium, characteristics:	Vegetable and animal oils and fats, mineral oils and fats, (fuel, fuel oil), dilute acids, alkalis, brines, water, air, gases (butane, ethane, methane, propane), hydraulic oils. <u>NOT resistant to:</u> aromatic and chlorinated hydrocarbons, glycol-based vehicle brake fluids and ozone contamination.	Resistant to oils and greases as in NBR materials and to hot water up to 100 °C, good resistance to hypoid gear oils up to +130 °C. <u>NOT resistant to:</u> aromatic and chlorinated hydrocarbons, vehicle brake fluids.	Glycol based brake fluids, high temperature air, oxygen, hot water, high molecular weight chlorinated aromatic hydrocarbons. <u>NOT resistant to:</u> concentrated acids and alkalis, water above 100°C, steam	High temperature vegetable and animal oils and fats and mineral oils and fats, various chemicals (aromatic, aliphatic, chlorinated hydrocarbons), highly oxidising acids, vacuum, petrol. <u>NOT resistant to:</u> acetone, amines, alkalis, vehicle brake fluids, acetic acid, hot water and steam.	Hot water, steam, air, vehicle brake fluids up to 150 °C, glycol-based fluids, dilute acids, alkalis. Excellent abrasion resistance, resistance to ozone, UV and ageing. <u>NOT resistant to:</u> any petroleum products (lubricants, fuels) and hydro

*The typical lower value is -30 °C. In case of cold resistant material type the lower value could be reach the -50 °C.